

Architects - These concepts have been expanded and modified to afford you design freedom. Please contact your Kawneer representative for further assistance. The extrusions and window types illustrated in this catalog are standard products for Kawneer.

FEATURES **2**

PICTORIAL VIEW **3**

FIXED FRAMING DETAILS **4**

MISCELLANEOUS DETAILS **5**

VENT DETAILS **6, 7**

THERMAL TRANSMITTANCE **8**

STRUCTURAL LIMITATIONS **9**

LAWS AND BUILDING AND SAFETY CODES GOVERNING THE DESIGN AND USE OF GLAZED ENTRANCE, WINDOW, AND CURTAIN WALL PRODUCTS VARY WIDELY. KAWNEER DOES NOT CONTROL THE SELECTION OF PRODUCT CONFIGURATIONS, OPERATING HARDWARE, OR GLAZING MATERIALS, AND ASSUMES NO RESPONSIBILITY THEREFOR.

Metric (SI) conversion figures are included throughout these details for reference. Numbers in parentheses () are millimeters unless otherwise noted.

The following metric (SI) units are found in these details:

- m - meter
- cm - centimeter
- mm - millimeter
- s - second
- Pa - pascal
- MPa - megapascal

Kawneer reserves the right to change configurations without prior notice when deemed necessary for product improvement.

Laws and building and safety codes governing the design and use of glazed entrance, window, and curtain wall products vary widely. Kawneer does not control the selection of product configurations, operating hardware, or glazing materials, and assumes no responsibility therefor.

Kawneer reserves the right to change configuration without prior notice when deemed necessary for product improvement.
© Kawneer Company, Inc., 2010

FEATURES

24mm ISOWEB® glass-reinforced nylon 6/6 thermal break provides:

- Improved condensation resistance and thermal transmittance performance capability
- Rigid profiles with composite structural performance
- Exterior / interior finish options

Meets or exceeds the highest performance levels of CSA standard CAN/CSA-A440 Windows

Vented and drained rain screen glazing cavity

Coped joinery with screw spline fastening

Recessed interior leg on perimeter section to accept air and / or vapour barrier membranes

Glazing flanges on same plane providing flush appearance

Distinctive "Top Hat" accent feature

Accommodates 25mm and 44mm sealed unit thicknesses

Glass installed and replaced from interior

Tremco VISIONstrip® exterior glazing system

EPDM rubber air seal gasket along perimeter of 25mm sealed unit

EPDM rubber interior gasket pre-loaded to snap-in glass stop

Accepts Ventrow inserts

Accepts a full range of Kawneer's series AA900 project-in, project-out and casements vents

- 45° mitered vent and frame corners
- Accentuated tubular profiles
- Factory fabricated and assembled
- Euro-groove multi-point locking hardware
- Multiple locking handle styles and finishes
- Triple glazing available

Laws and building and safety codes governing the design and use of glazed entrance, window, and curtain wall products vary widely. Kawneer does not control the selection of product configurations, operating hardware, or glazing materials, and assumes no responsibility therefor.

Kawneer reserves the right to change configuration without prior notice when deemed necessary for product improvement.
© Kawneer Company, Inc., 2010

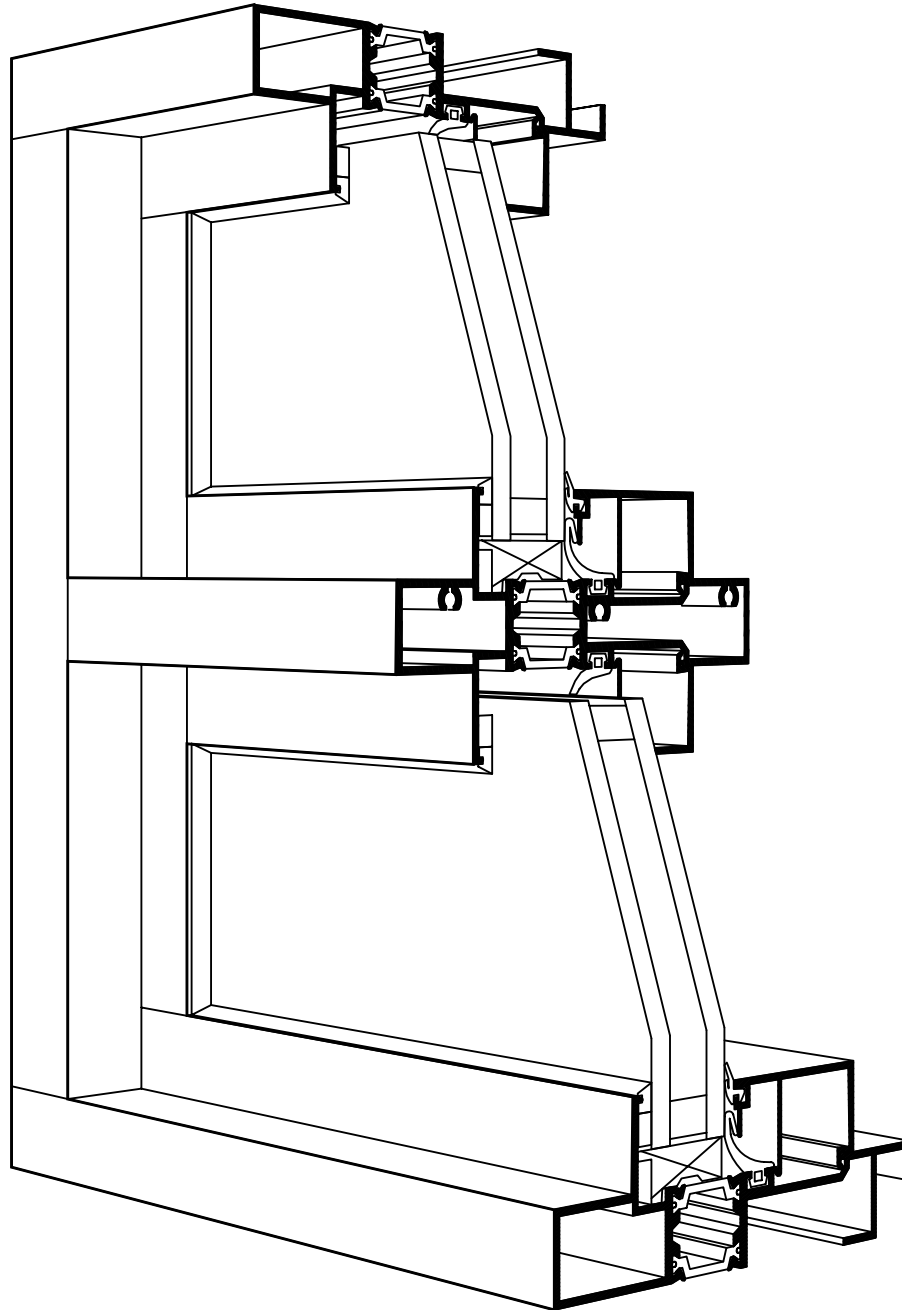

Laws and building and safety codes governing the design and use of glazed entrance, window, and curtain wall products vary widely. Kawneer does not control the selection of product configurations, operating hardware, or glazing materials, and assumes no responsibility therefor.

Kawneer reserves the right to change configuration without prior notice when deemed necessary for product improvement.

© Kawneer Company, Inc., 2010

SCALE 1/4 FULL SIZE

PUNCHED OPENING WITH VERTICALS

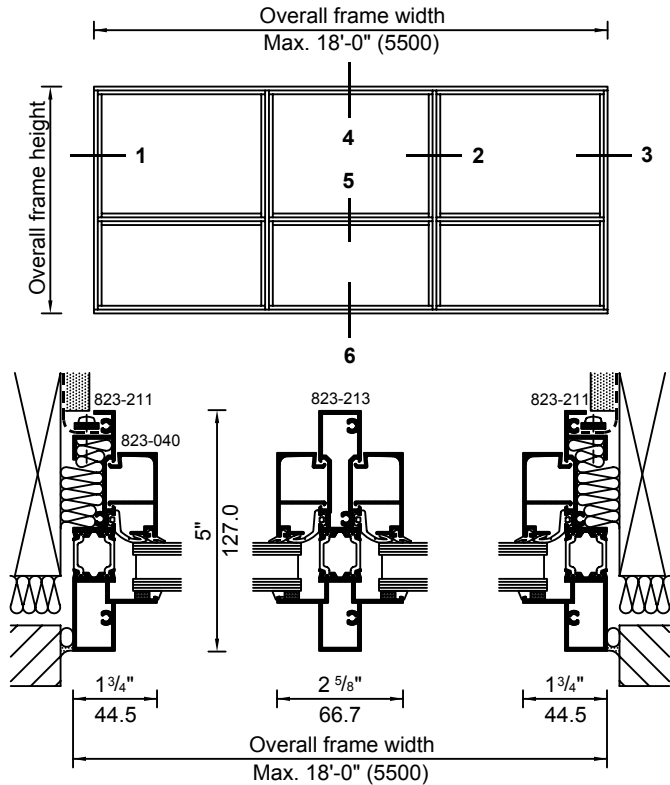

1 JAMB
2 TUBULAR MULLION
3 JAMB

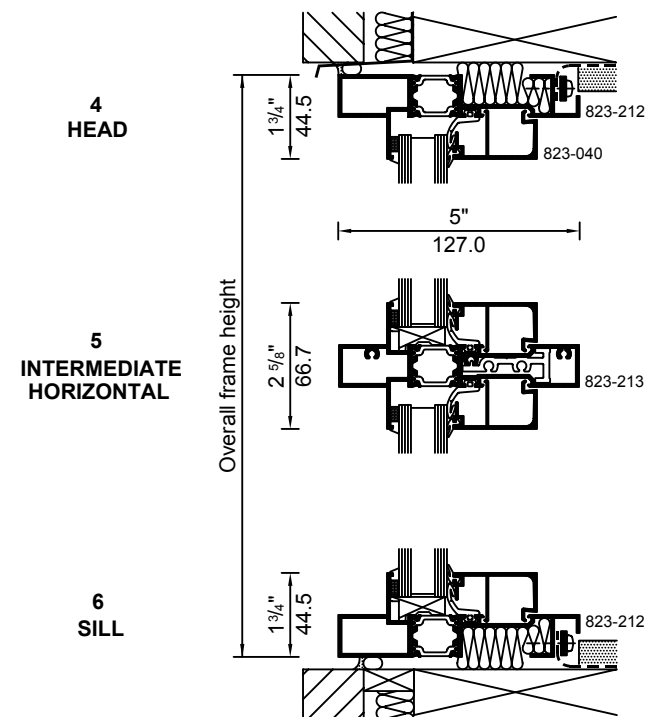

4 HEAD

5 INTERMEDIATE HORIZONTAL

6 SILL

MULTI-MODULAR STRIP WINDOW

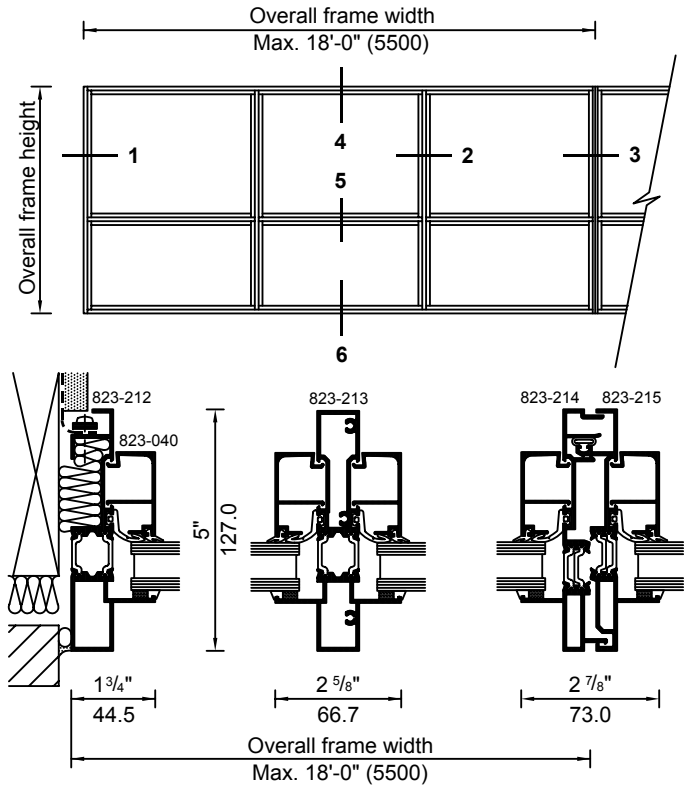

1 JAMB
2 TUBULAR MULLION
3 MULTI-MODULAR COUPLING MULLION

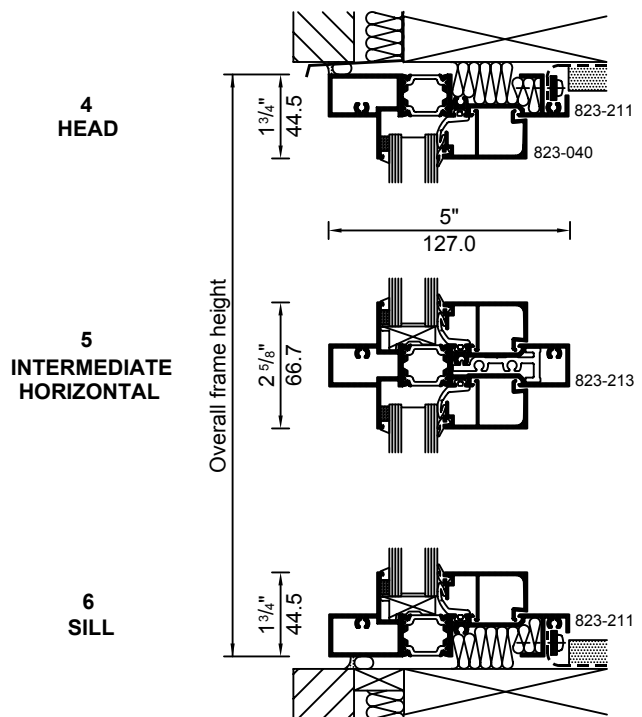

4 HEAD

5 INTERMEDIATE HORIZONTAL

6 SILL

Laws and building and safety codes governing the design and use of glazed entrance, window, and curtain wall products vary widely. Kawneer does not control the selection of product configurations, operating hardware, or glazing materials, and assumes no responsibility therefor.

Kawneer reserves the right to change configuration without prior notice when deemed necessary for product improvement.
© Kawneer Company, Inc., 2010

SCALE 1/4 FULL SIZE

TRIPLE GLAZING
(ACCEPTS 44mm SEALED UNITS)

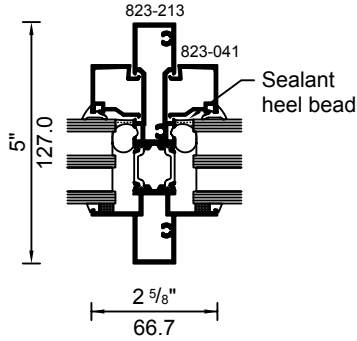

DEFLECTION HEAD
(ALLOWS ± 5/8" (15.9) MOVEMENT)

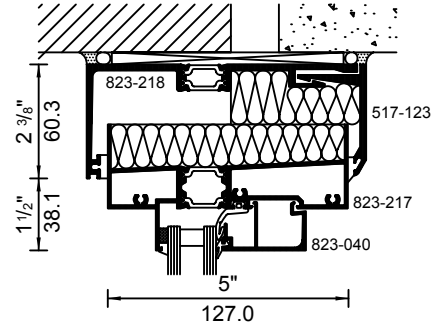

90° INSIDE CORNER

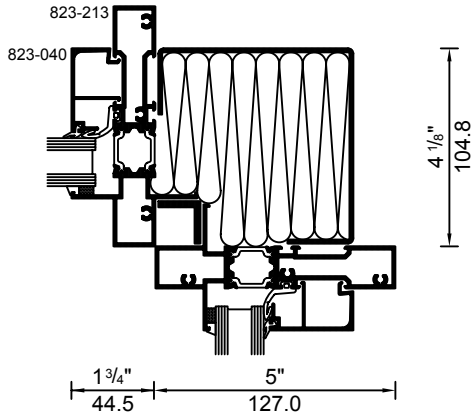

90° OUTSIDE CORNER

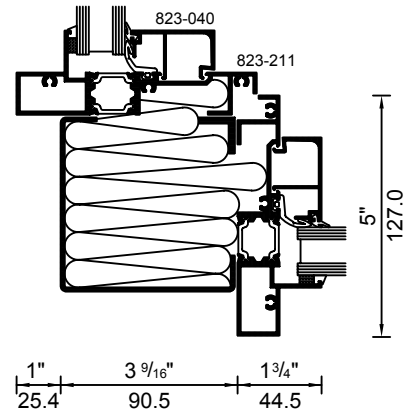

TYPICAL SILL DETAILS

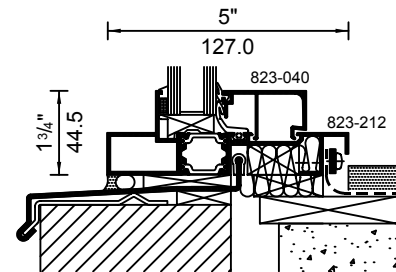
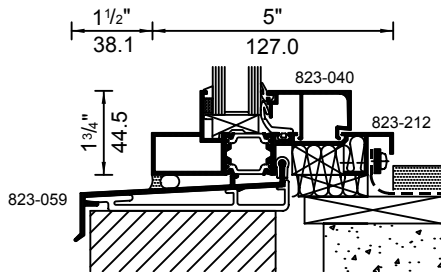

Laws and building and safety codes governing the design and use of glazed entrance, window, and curtain wall products vary widely. Kawneer does not control the selection of product configurations, operating hardware, or glazing materials, and assumes no responsibility therefor.

Kawneer reserves the right to change configuration without prior notice when deemed necessary for product improvement.

© Kawneer Company, Inc., 2010

SCALE 1/4 FULL SIZE

NOTE: TYPICAL WINDOW CONFIGURATIONS SHOWN, REFER TO AA™900 ISOWEB® WINDOW PRODUCT LITERATURE FOR PERFORMANCE RATINGS, SIZE LIMITATIONS AND AVAILABLE OPTIONS.

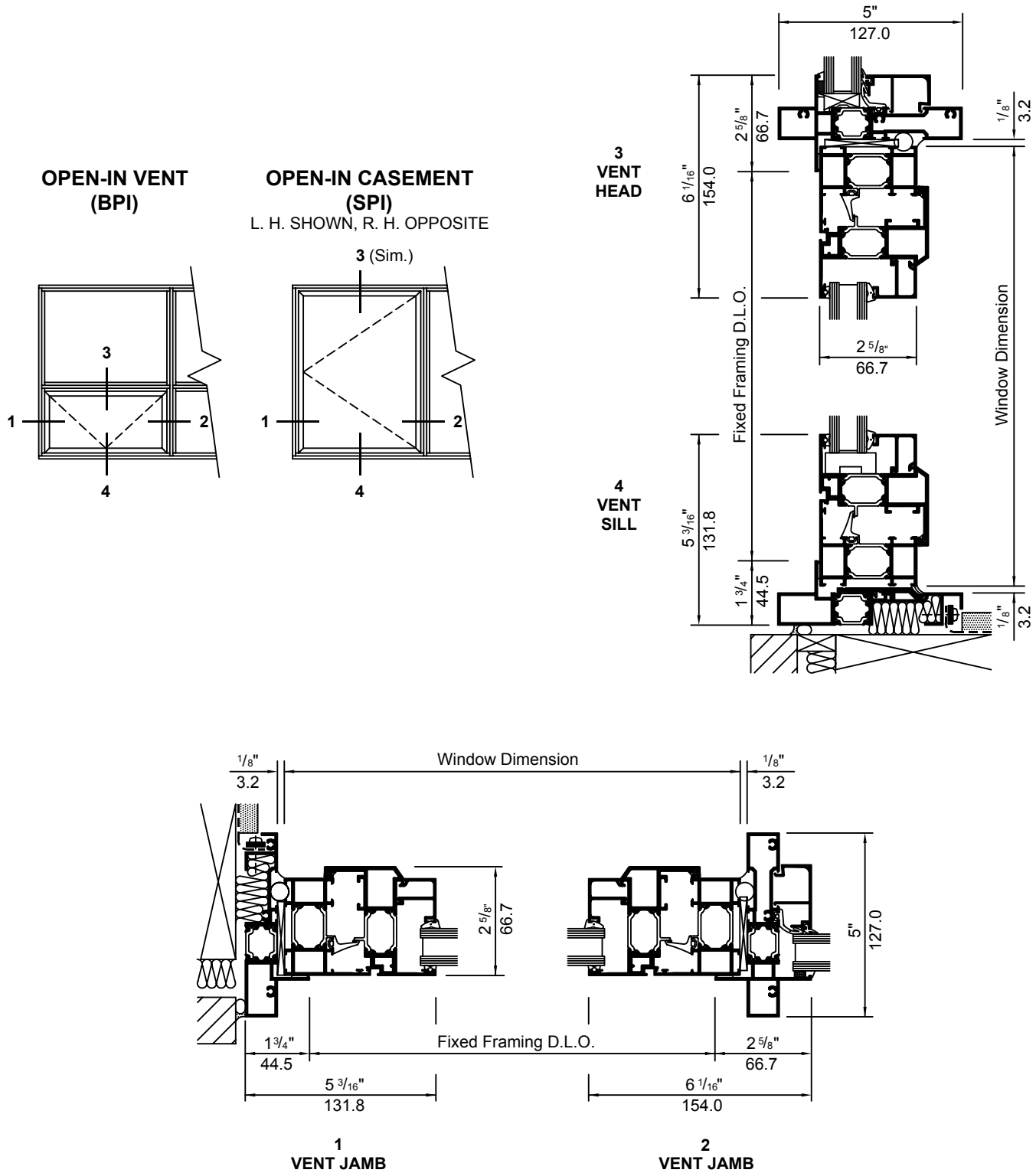

Laws and building and safety codes governing the design and use of glazed entrance, window, and curtain wall products vary widely. Kawneer does not control the selection of product configurations, operating hardware, or glazing materials, and assumes no responsibility therefor.

Kawneer reserves the right to change configuration without prior notice when deemed necessary for product improvement.
© Kawneer Company, Inc., 2010

SCALE 1/4 FULL SIZE

NOTE: TYPICAL WINDOW CONFIGURATIONS SHOWN, REFER TO AA™ 900 ISOWEB® WINDOW PRODUCT LITERATURE FOR PERFORMANCE RATINGS, SIZE LIMITATIONS AND AVAILABLE OPTIONS.

Laws and building and safety codes governing the design and use of glazed entrance, window, and curtain wall products vary widely. Kawneer does not control the selection of product configurations, operating hardware, or glazing materials, and assumes no responsibility therefor.

Kawneer reserves the right to change configuration without prior notice when deemed necessary for product improvement.

© Kawneer Company, Inc., 2010

OPEN-OUT VENT (TPO)

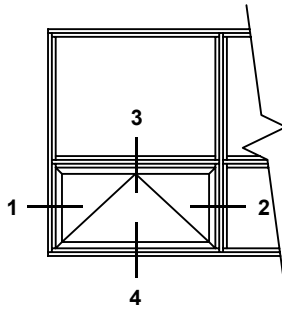

OPEN-OUT CASEMENT (SPO)

R. H. SHOWN, L. H. OPPOSITE

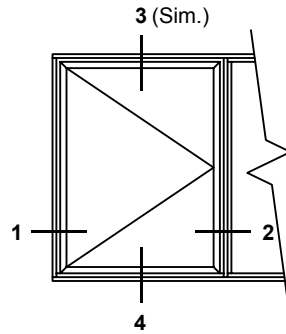

3 VENT HEAD

4 VENT SILL

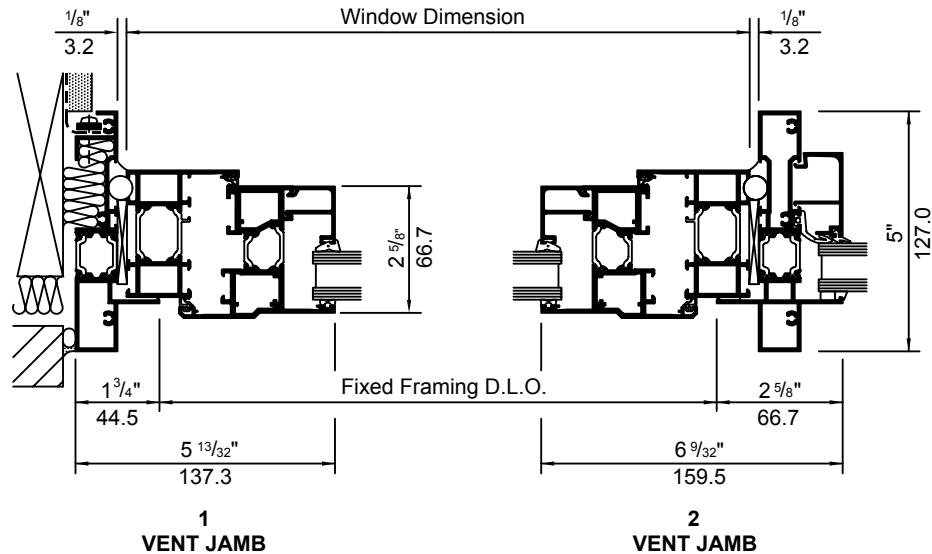
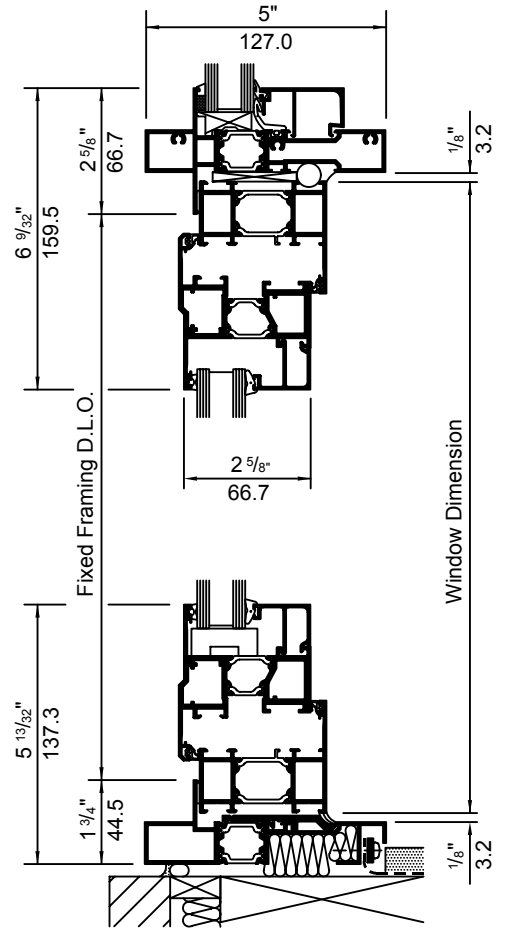

For some regions and projects there may be minimum energy efficiency requirements for the building envelope, and its components, including windows. The shading coefficient (SC) and the thermal transmittance (U - value) of the window is then required to determine whether the building design complies with the specified energy requirements. Shading coefficient depends on the glass selected and should be obtained from the glass supplier. The U - value of the window varies with the type of glass and sealed unit edge construction, the window frame, and the relative areas of these components.

The window thermal transmittance values (U - values) shown in the chart below are based on CSA - A440.2 "Energy Performance Evaluation of Windows and Sliding Glass Doors." U - values of the center of glass, edge of glass, and frame areas were computed using the VISION and FRAME thermal simulation programs. Overall window U - values were calculated using the following relationship:

$$U_w = (U_c A_c + U_e A_e + U_f A_f) / A_w$$

where

U_w = U-value of complete window product

U_c = calculated center of glass U-value

U_e = calculated edge of glass U-value

U_f = calculated frame U-value

A_c = center of glass area

A_e = edge of glass area

A_f = frame area

A_w = total window area

OVERALL WINDOW U-VALUE (U_w)

For fixed and operating window configurations as shown with height (h) equal to width (w).

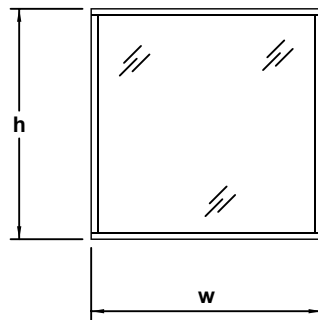

SEALED UNIT GLAZING TYPE

A = 6mm clear / 1/2" air / 6mm low-e¹ / metal spacer

B = 6mm clear / 1/2" argon / 6mm low-e¹ / metal spacer

C = 6mm clear / 1/2" argon / 6mm low-e¹ / warm edge spacer³

D = 6mm clear / 1/2" argon / 6mm low-e² / warm edge spacer³

E = 6mm clear / 1/2" argon / 6mm low-e¹ / 1/2" argon / 6mm low-e¹ / metal spacer

F = 6mm clear / 1/2" argon / 6mm low-e² / 1/2" argon / 6mm low-e² / warm edge spacer³

1 - low-e coating emittance = 0.1

2 - low-e coating emittance = 0.03

3 - Edgetech Super "U" Spacer®

NOTES: THE ABOVE SEALED UNIT GLAZING OPTIONS ARE PRESENTED FOR THE PURPOSES OF ILLUSTRATING THERMAL PERFORMANCE CAPABILITIES.

FOR WINDOWS WITH HEIGHT NOT EQUAL TO WIDTH, WHEN ADDING INTERMEDIATE VERTICALS OR HORIZONTALS, OR DIFFERENT GLASS INFILL, THE OVERALL WINDOW U - VALUE MAY VARY.

THE SPECIFIER SHOULD SELECT GLASS TO MEET THE PERFORMANCE REQUIREMENTS OF THE PROJECT.

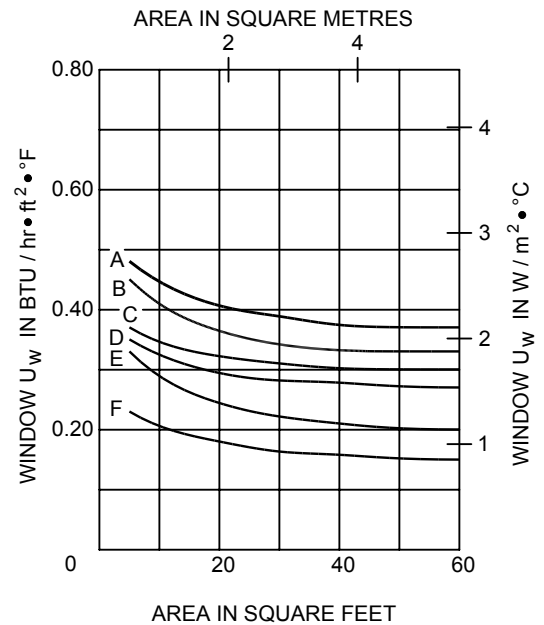

Laws and building and safety codes governing the design and use of glazed entrance, window, and curtain wall products vary widely. Kawneer does not control the selection of product configurations, operating hardware, or glazing materials, and assumes no responsibility therefor.

Kawneer reserves the right to change configuration without prior notice when deemed necessary for product improvement.

© Kawneer Company, Inc., 2010

Calculations are based on CAN3-S157 "Strength Design in Aluminum" in accordance with the National Building Code of Canada and an allowable deflection of 1/175 of mullion span.

WINDLOAD LIMITATIONS

WITHOUT HORIZONTALS

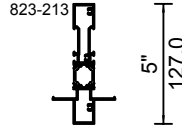
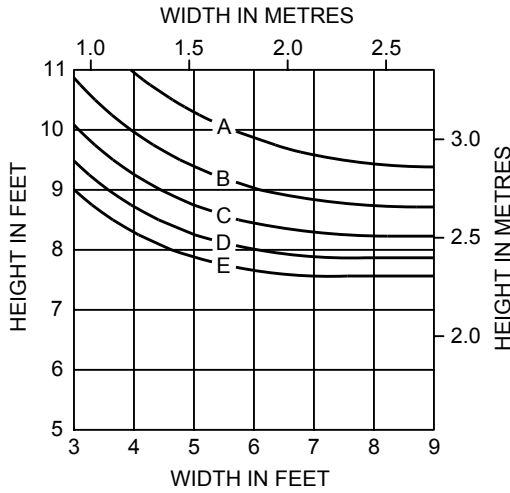

- A = 15 p.s.f. (0.72 kPa.)
- B = 20 p.s.f. (0.96 kPa.)
- C = 25 p.s.f. (1.20 kPa.)
- D = 30 p.s.f. (1.44 kPa.)
- E = 35 p.s.f. (1.68 kPa.)

WITH HORIZONTALS

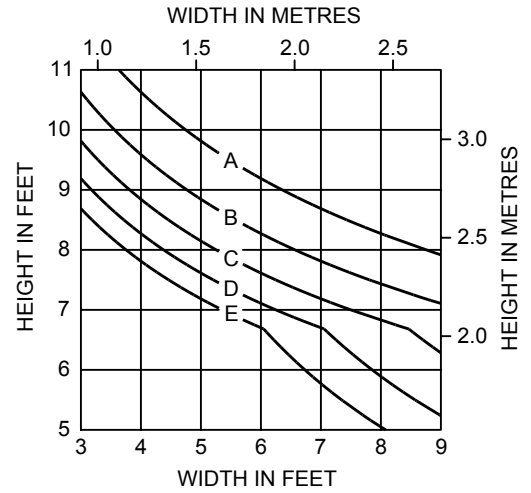

WITHOUT HORIZONTALS

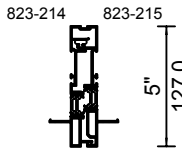
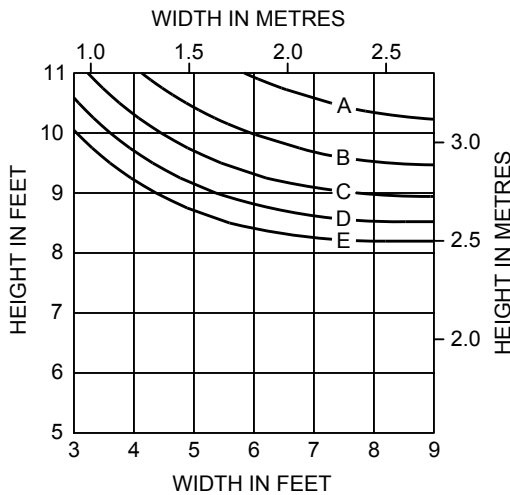

WITH HORIZONTALS

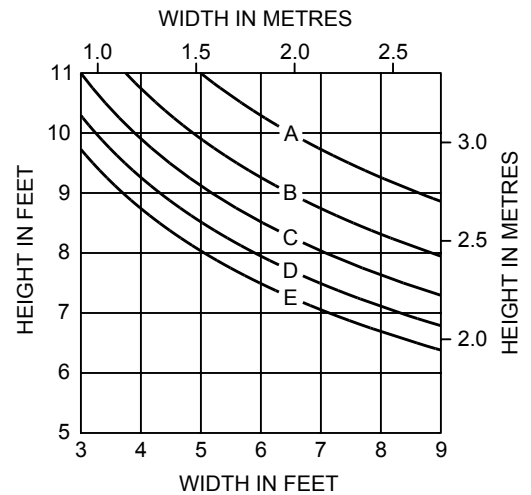

DEADLOAD LIMITATIONS

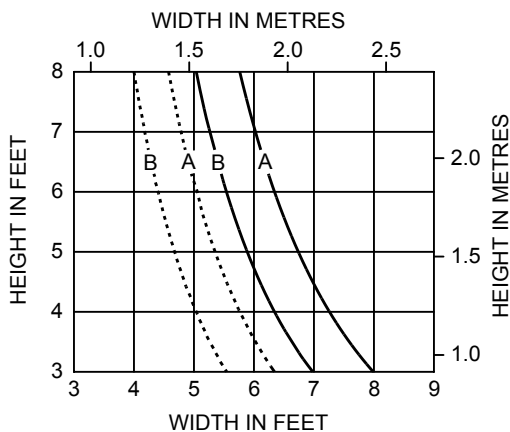

- Intermediate Horizontal Over Ventilator (Maximum Deflection 1/16")
- Intermediate Horizontal Over Fixed Lite (Maximum Deflection 1/8")

Curves are for sealed units with setting blocks 3" (76 mm) from the ends of the lite.

Intermediate Horizontal 823-213

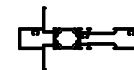

I = 0.20 in⁴ (8.24 x 10⁴ mm⁴)
S = 0.25 in³ (0.41 x 10⁴ mm³)

- A - Double glazed sealed unit with (2) 6mm lites.
- B - Triple glazed sealed unit with (3) 6mm lites

Laws and building and safety codes governing the design and use of glazed entrance, window, and curtain wall products vary widely. Kawneer does not control the selection of product configurations, operating hardware, or glazing materials, and assumes no responsibility therefor.

Kawneer reserves the right to change configuration without prior notice when deemed necessary for product improvement.

© Kawneer Company, Inc., 2010